

(2007/2008)

04 :

:

:( 12)

( 3)

$$K_e = 10^{-14} \quad 25^\circ\text{C}$$

. [ ]  
: /I

Na<sup>+</sup>

ClO<sup>-</sup>

. Cl<sup>-</sup>

$$K_{a1} = 3.2 \cdot 10^{-8}$$

. ( )

12°

J<sub>1</sub>

-

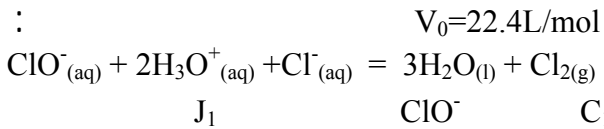

-1

J<sub>2</sub>

J<sub>1</sub>

-2

$$C_2 = 6.7 \cdot 10^{-2} \text{ mol/L}$$

ClO<sup>-</sup>

-3

Ka<sub>1</sub>

10.9

J<sub>2</sub>

pH

-4

:( liqueur de Dakin) /II

100

1.5°

C = 0.238 mol/L

HCO<sub>3</sub><sup>-</sup>

10 mg/L

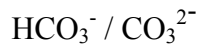

$$pK_{a2} = 10.3$$

 $K_{a2}$ 
 $( \quad )$ 
 $: 9.4$ 

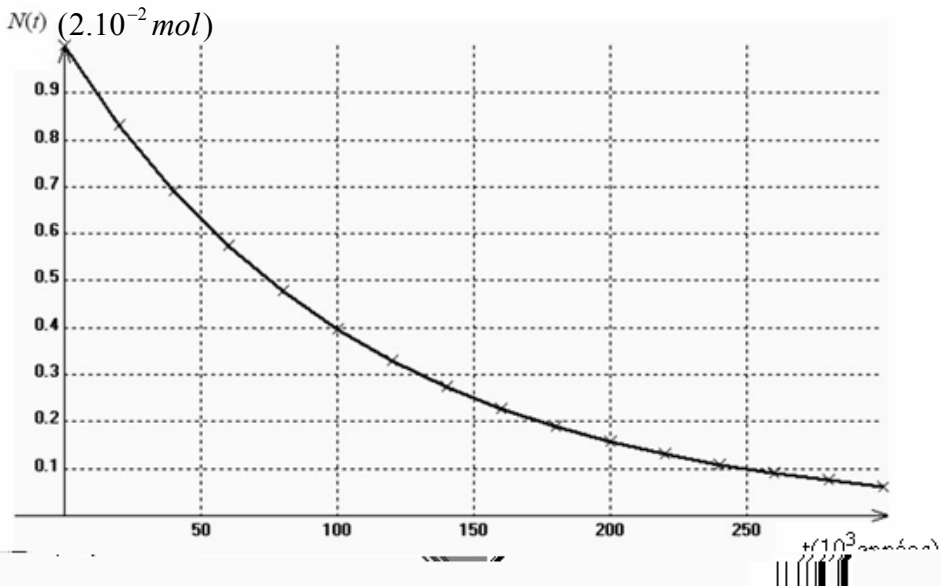
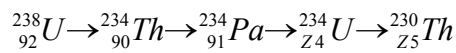
 $J_2$ 
 $:( \quad 4)$ 
 $.230$ 
 $^{230}\text{Th}$ 
 $230$ 

 $\alpha$   
 $_{88}\text{Ra}$ 
 $.230$ 
 $\lambda$ 
 $238$ 
 $230$ 

 $Z_5 \quad Z_4 :$ 

$$\frac{N(^{230}\text{Th})}{N(^{238}\text{U})}$$

 $230$ 
 ${}^{230}\text{Th} \quad {}^{238}\text{U}$ 
 $230$ 
 $A(t)$

$$A(t) = -\frac{dN(t)}{dt}$$

A(t)

$$A(t) = \lambda N(t)$$

$$\frac{N(^{230}\text{Th})}{N(^{238}\text{U})}$$

:( 2)

6.5m/s

t=0

$$f = Kv^2$$

-1

-2

6.5m/s

-3

$$g = 9.8\text{m/s}^2$$

M=90kg

-4

$$v = 2\sqrt{t}$$

0 ≤ t ≤ 5s

.f

-5

5mn

:( 3)

رسم الاهتزازات



الشكل-1

E

.I

( GBF )

R

E

(10 μ s/div) ( )

340m/s

E

- 1

:

(2- ) 2

- 2

الشكل-2

- 3

- 4

.II

(3 )

R

E

(10 μ s/div)

:

( )

-

الشكل-3

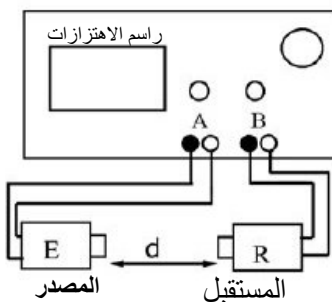

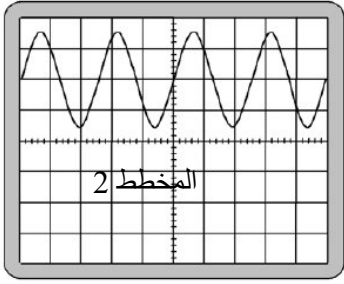

الشكل-4-

2.41 cm

( $E$ )  
 $(4 - ) 2$   
 $- 1$   
 $E$   $(4 - ) 2$   
 $- 2$   
 $R$   $E$   
 $d_1$   $- 3$

:( 4)  
 :( 4)

$n(g)$  100g n  
 $(S)$   
 $C_b = 0.10 \text{ mol/L}$   $(S)$   $V_s = 20 \text{ mL}$   
 $V_b$   $pH = f(V_b) :$

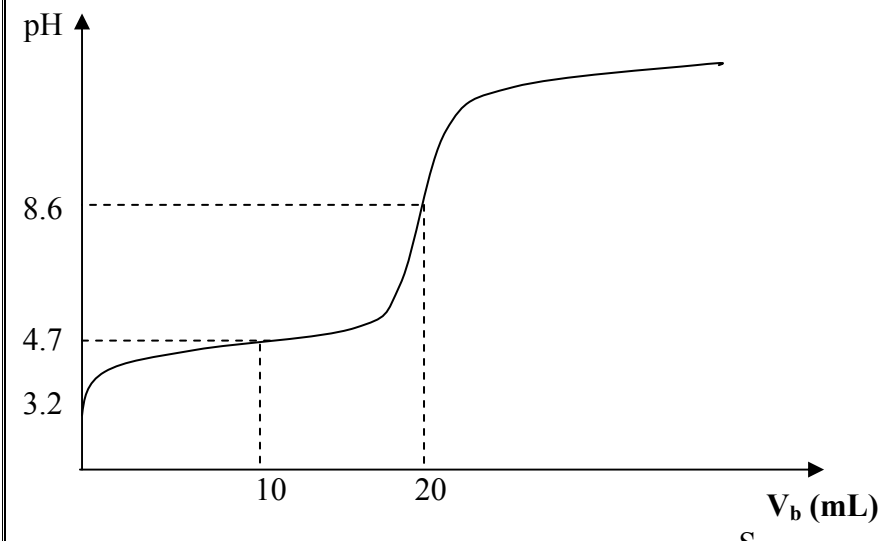

. S /1 1  
 . /2 1  
 2  
 . /1 3  
 . /2 3  
 (Qr)  
 . C (S) /1 4  
 100g /2 4  
 . /3 4

$\mu = 1.02 \cdot 10^{-3} \text{ g/l} :$

:( 4)

\_\_\_\_\_

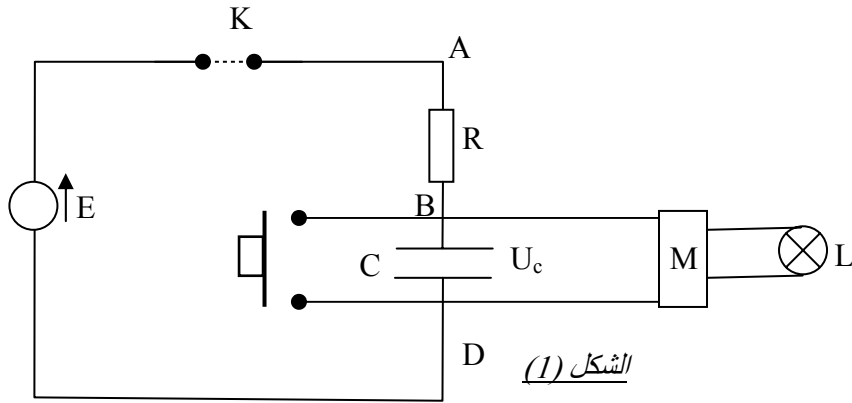

الشكل (1)

C R K E=30v  
M U<sub>1</sub>=20v  
)  
(

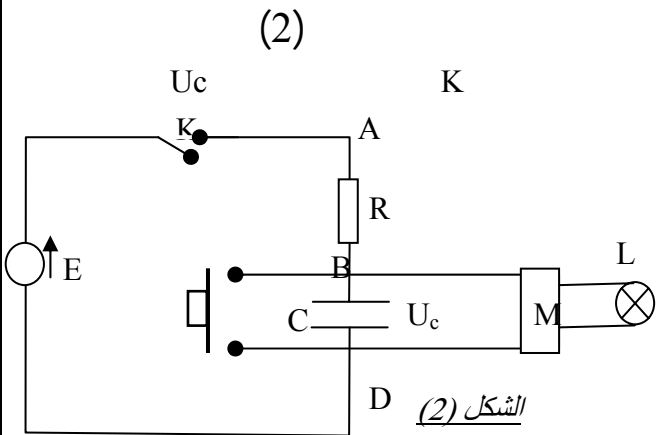

الشكل (2)

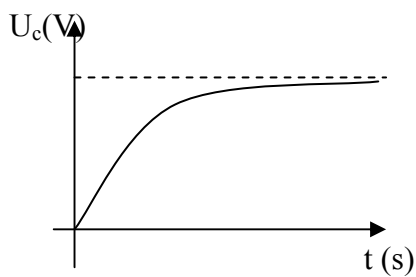

1

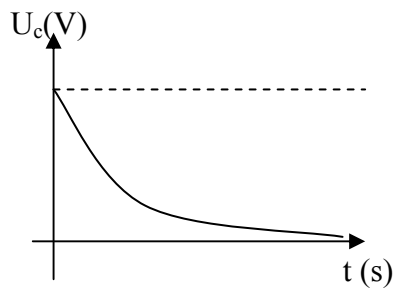

2

$$RC \frac{du_c}{dt} + u_c = E :$$

-2

:

$$U_c = Ae^{-t/\tau} \quad U_C = A(1 - e^{-t/\tau})$$

$$U_c(t) = \frac{C R E}{\tau} (1 - e^{-t/\tau})$$

-3

$$\tau = RC$$

/ -4

$$R = 100V \quad C = 200\mu F$$

/ -

(1)

- II

$U_1$

$U_c$

$t_0$

/1

$\tau$

(

)  $t_0$

/2

)

30s

(

$\tau$

$t_0$

/3