

2011 / 2010 :		
03 :	:	1 :
/ :		

2011 -02 - 15: :

التمرين الأول : ( 04 )

I. أكمل أماكن الفراغات بما يناسبها.

$$3 \text{ dm}^3 = \dots\dots\dots \text{ cm}^3 = \dots\dots\dots \text{ L}$$

$$150 \text{ m} = \dots\dots\dots \text{ dm} = \dots\dots\dots \text{ cm} = \dots\dots\dots \text{ mm}$$

$$7 \text{ kg} = \dots\dots\dots \text{ hg} = \dots\dots\dots \text{ dag} = \dots\dots\dots \text{ g}$$

.II

( :

(

(ج

.III

(. ) - -

..... •  
..... •

( 04 ) :

.I

.2 1

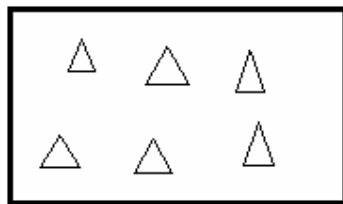

الوثيقة 2

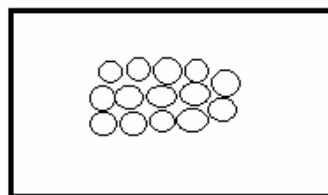

الوثيقة 1

2cm

3cm

.II

. 1cm

. cm<sup>3</sup>

(1

.46mL

40mL

(2

(

(

(→

( 04) :

.I

(1

(2

(3

- .II

(1 .III

(2

(3

(4

( 08) :

.I

3-

(1

.5 , 4 , 3 , 2 , 1 :

(2

B A .II

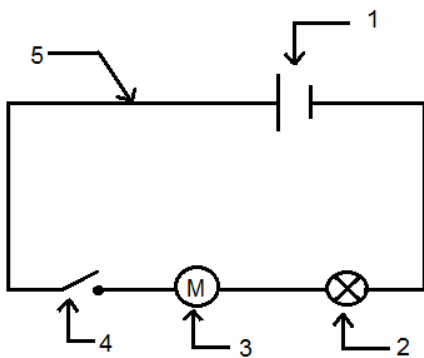

الوثيقة 3

.4-

-

-

:

(1

(2

(3

.III



الوثيقة 4